

DIRTY WORK PACK

16CC IHPU
HYDRAULIC POWER UNIT
PRODUCT NO.: 105536

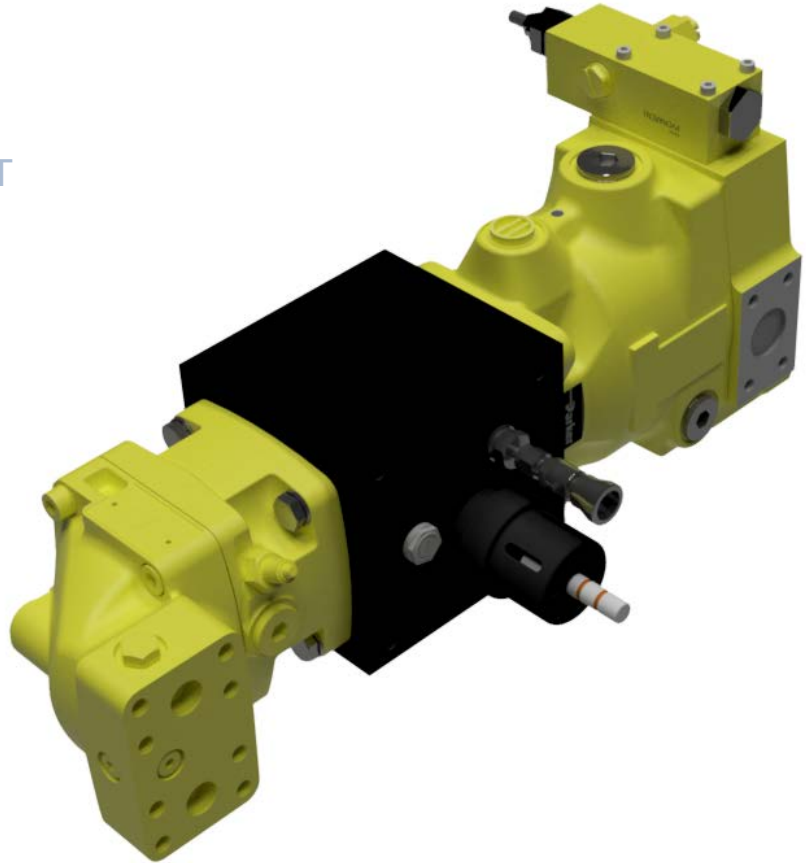

The Dirty Work Pack Unit is used to reduce the risk of contamination in the main ROV hydraulic system. By using this equipment, you will get two completely separate oil circuits and avoid concerns about contamination in your hydraulic system.

The Dirty Oil Pack is an Isolated Hydraulic Power Unit (IHPU) that can be easily incorporated into a ROV hydraulic system to provide an isolated hydraulic supply for driving tooling and equipment that may potentially otherwise cause contamination to the main ROV hydraulic supply.

Hook-up to the ROV is quick and simple by connecting a supply, return and drain line to a ROV valve pack function.

The DWP can be delivered as a complete unit with oil filters and reservoirs / compensators. The skid can be assembled as a backpack for rear end interface, or a belly skid for interface underneath the ROV.

FEATURES

- Compact design
- Adjustable to customer requirements
- Rated to full ocean depth
- Allows auxiliary tools and equipment to be independent from the main hydraulic system
- Service and user friendly
- Remote pressure control option
- Customized pressure and flow setup
- Utilizes industry standard parts
- Up to 345 Bar / 5000PSI output pressure

Specifications

General Technical Data

| | | |
|---------------------------|-------------|-----------------|
| Product No. | | 105536 |
| Weight in air / submerged | KG | 38Kg / 32Kg |
| Dimensions (mm) | (W x H x L) | 218 x 253 x 531 |

Hydraulic Technical Data

| | | |
|----------------------|-----------------------|------------|
| Pump Displacement | cm ³ /rev. | 16 |
| Max. supply pressure | Bar (PSI) | 210 (3000) |
| Max. supply flow | LPM (GPM) | 90 (23.7) |
| Max. output flow @ | Bar (PSI) | 210 (3000) |
| Flow | LPM (GPM) | 48 (13.2) |

Efficiency is rated to 66%

Interfaces

| | |
|------------------------|--|
| Motor Supply Port | A - 3/4" SAE Code 62 (6000PSI) ISO6162 |
| Motor Return Port | B - 3/4" SAE Code 62 (6000PSI) ISO6162 |
| Motor Drain Port | C - M22 x 1.5 Female |
| Pump Pressure Port | D - 3/4" SAE Code 62 (6000PSI) ISO6162 |
| Pump Suction Port | E - 1-1/4" SAE Code 61 (3000PSI) ISO6162 |
| Pump Drain Port | F - G 1/2" BSP Female |
| Pump Regulator PC Port | G - G 1/4" BSP Female |
| Bellhousing fill port | H - SWG SS-QC4-B-400 Female |

What's in the box

- 105536 – Dirty Work Pack
- 105536 – Usermanual
- 109771 – Aluminum Transit Box

Options and Accessories

- Compensator / Reservoir
- Pressure and Return Filters
- Proportional Pump Regulator
- Pump Trip Module
- Pump Flush Kit
- Hoses from ROV to DWP
- Spares Kit

